



EVOLUTION™
RAPID EVOLUTION

2002 Series FRU Installation and Replacement Guide

Copyright Protected Material 2009. All rights reserved. R/Evolution and the R/Evolution logo are trademarks of Dot Hill Systems Corp. All other trademarks and registered trademarks are proprietary to their respective owners.

The material in this document is for information only and is subject to change without notice. While reasonable efforts have been made in the preparation of this document to assure its accuracy, changes in the product design can be made without reservation and without notification to its users.



Adobe PostScript

Contents

Preface	9
Intended audience	9
Prerequisites	9
Related documentation	9
Document conventions and symbols	10
1 FRUs	11
Available FRUs	11
2 Procedures	17
Replacing a chassis	17
Replacing a controller or expansion module	17
Before you begin	17
Verifying partner firmware is enabled	17
Verifying component failure	18
Removing the controller module	18
Installing the controller module	19
Verifying component replacement	20
Installing a controller (additional module)	20
Replacing a drive module	20
Before you begin	20
Removing air management modules	21
Installing drive modules	21
Verifying component installation	22
Replacing a power supply unit	22
Verifying component failure	22
Before you begin	22
Disconnecting a power cable	22
Removing a power supply	23
Installing a power supply unit	24
Connecting a power cable	24
Replacing bezel ears	25
Before you begin	25
Removing the bezel ears	26
Installing the bezel ears	26
Replacing a Fibre Channel SFP	27
Before you begin	27
Removing an SFP module	27
Installing an SFP module	27
Index	29

Figures

1	Storage system exploded view (2U24)	12
2	Storage system assembly (2U24)	13
3	Storage system architecture — partial component assembly (2U24)	13
4	Storage system exploded view (2U12)	15
5	Storage system assembly (2U12)	15
6	Storage system architecture — partial component assembly (2U12)	16
7	Disengaging a controller module	18
8	Extracting a controller module	19
9	Removing a controller module	19
10	Inserting a controller module	20
11	Disengaging an air management sled (AMS)	21
12	Removing an AMS	21
13	Installing a drive module	22
14	Removing a power supply unit	23
15	Orienting a power supply unit	24
16	Replacing bezel ears — 2U24 models	25
17	Replacing left bezel ears — 2U12 models	25
18	Replacing right bezel ears — 2U12 models	26
19	Typical SFP module	27

Tables

1	Document conventions	10
2	Available FRUs for 2002 Series products using 24-drive enclosure	11
3	Available FRUs for 2002 Series products using 12-drive enclosure	13

Preface

This guide identifies 2002 Series FRUs (field replaceable units), and describes how to install or replace them. The following products comprise the 2002 Series product line:

Fibre Channel Controller Enclosure

- 2722
- 2732

Serial-attached SCSI Controller Enclosure

- 2522
- 2532

Internet SCSI Controller Enclosure

- 2322
- 2332

Intended audience

This guide is intended for use by system administrators and technicians who are experienced with the following:

- Direct attach storage (DAS) or storage area network (SAN) management
- Network administration
- Network installation
- Storage system installation and configuration

Prerequisites

Prerequisites for installing and configuring this product include familiarity with:

- Servers and computer networks
- Fibre Channel (FC), Serial-attached SCSI (SAS), Internet SCSI (iSCSI), and Ethernet protocols

Related documentation

In addition to this guide, please refer to other documents for this product line:

- R/Evolution 2002 Series Setup Guide
- R/EvolutionRackmount Bracket Kit Installation
- R/Evolution 2002 Series Installation sheets:
 - 2722/2732 Installation
 - 2522/2532 Installation
 - 2322/2332 Installation
- R/Evolution 2002 Series RAIDar User Guide
- R/Evolution 2002 Series CLI Reference Guide
- Online help for R/Evolution 2002 Series management interfaces
- R/Evolution Installing Optional Software for Microsoft Windows® Server
- R/Evolution 2002 Series Release Notes
- R/Evolution Product Regulatory Compliance and Safety

See Dot Hill's customer resource center (CRC) web site for additional information:

crc.dothill.com

Select R/Evolution Products and go to R/Evolution2002 Series.

Document conventions and symbols

Table 1 Document conventions

Convention	Element
Navy blue text	Cross-reference links and e-mail addresses
Navy blue text	Web site addresses
Bold font	<ul style="list-style-type: none">• Key names• Text typed into a GUI element, such as into a box• GUI elements that are clicked or selected, such as menu and list items, buttons, and check boxes
<i>Italics font</i>	Text emphasis
Monospace font	<ul style="list-style-type: none">• File and directory names• System output• Code• Text typed at the command-line
<i>Monospace, italic font</i>	<ul style="list-style-type: none">• Code variables• Command-line variables
Monospace, bold font	Emphasis of file and directory names, system output, code, and text typed at the command line

 **WARNING!** Indicates that failure to follow directions could result in bodily harm or death.

 **CAUTION:** Indicates that failure to follow directions could result in damage to equipment or data.

 **IMPORTANT:** Provides clarifying information or specific instructions.

 **NOTE:** Provides additional information.

 **TIP:** Provides helpful hints and shortcuts.

1 FRUs

Available FRUs

 **NOTE:** The tables and associated illustrations herein show FRUs for the 2002 Series of products.

FRUs and FRU make-up are subject to change independent of documentation versions. See Dot Hill's customer resource center (CRC) web site for the most current information:

crc.dothill.com

Select Interoperability Matrix for latest compatibility data.

Table 2 (below) lists FRUs for 2.5" 24-drive enclosure models (2U24); whereas Table 3 on page 13 lists FRUs for 3.5" 12-drive enclosure models (2U12). The table and its supporting illustrations (following) describe 2722/2522/2322 FRUs.

Table 2 Available FRUs for 2002 Series products using 24-drive enclosure

Item	FRU description	Spares part number
1	DISK DRIVES	—
	a) 36-GB 2.5" SAS, 15K rpm	PFRUKF29-01
	b) 72-GB 2.5" SAS, 15K rpm	PFRUKF28-01
	c) 146-GB 2.5" SAS, 15K rpm, 6Gb	PFRUKF35-01
	d) AIR MANAGEMENT SLED (AMS), 2.5"	PFRUKF31-01
2	EAR KIT	—
	a) Left ear assembly	PFRUKK01-01
	b) Right ear assembly	PFRUKK02-01
3	CHASSIS	PFRUKA02-01
4	HDD MIDPLANE (included with chassis)	—
5	CONTROLLER MIDPLANE (included with chassis)	—
6	POWER SUPPLIES (one shown)	—
	a) AC DISK ENCL, POWER SUPPLY	PFRUKE01-01
	b) DC DISK ENCL, POWER SUPPLY	PFRUKE02-01
7	ENCLOSURE, CONTROLLER MODULE (one shown)	—
	a) 2722/2732, IO, FC, RAID, 1024-MB	PFRUKC13-01
	b) 2522/2532, SAS, IO, RAID, 1024-MB	PFRUKC14-01
	c) 2322/2332, iSCSI, IO, RAID, 1024-MB	PFRUKC21-01
8	SFP, XCVR (applies to 2722/2732 only)	PFRUKK06-01
9	CONTROLLER ENCLOSURE COVER (included with chassis)	—
Not shown	ENCLOSURE, I/O MODULE (ordered separately)	—
	a) 2122, 1-IOM, SAS Connection	PFRUKC15-01
	b) I/O module blank	PFRUKC04-01

Table 2 Available FRUs for 2002 Series products using 24-drive enclosure

Item	FRU description	Spares part number
Not shown	RAIL KIT (ordered separately, <i>not</i> included in BOM)	—
	Rack Mount Kit, Shelf, Short, All HW 22.5" - 31"	FHDW017-02
	Rack Mount Kit, Shelf, Long, All HW 25" - 36"	FHDW018-02
Not shown	CABLE KIT (Cable Pkg: SAS-8470 to mini-SAS-8088 4x0.6m)	PFRUKL02-01
Not shown	CABLE KIT (Cable Pkg: DB9-M to DB9-F; CLI (micro DB9))	PFRUKL01-01

 **NOTE:** The following illustrations visually describe [Table 2](#) components:

- Exploded view — [Figure 1](#) on page 12
- Assembly — [Figure 2](#) on page 13
- Internal components assembly — [Figure 3](#) on page 13

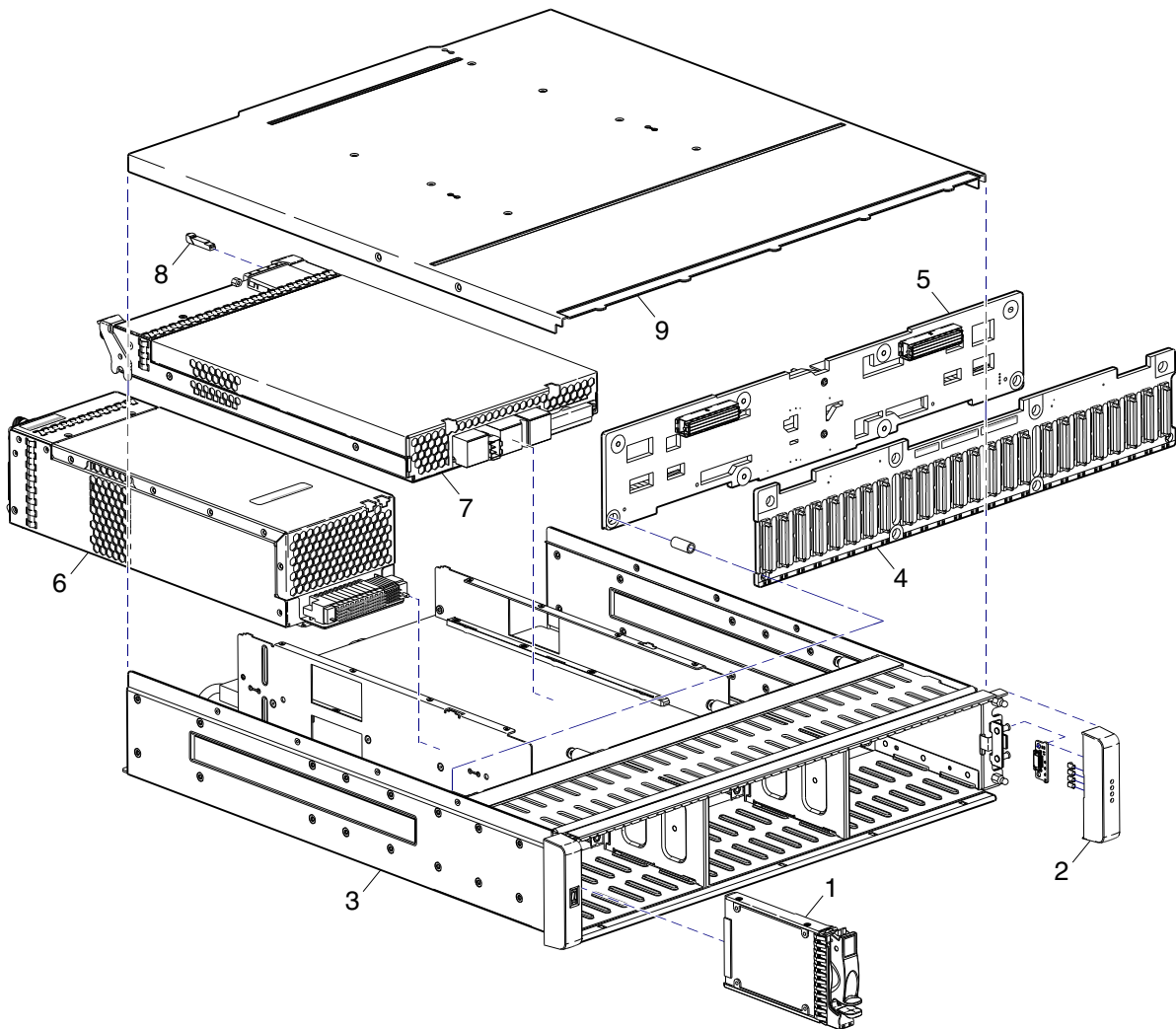

Figure 1 Storage system exploded view (2U24)

Figure 1 (above) and Figures 2 and 3 (below) illustrate 24-drive enclosure models: 2722/2522/2322.

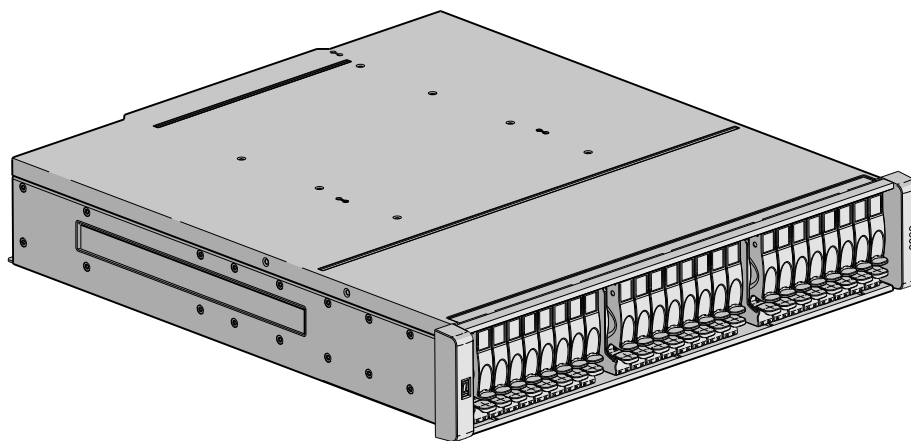

Figure 2 Storage system assembly (2U24)

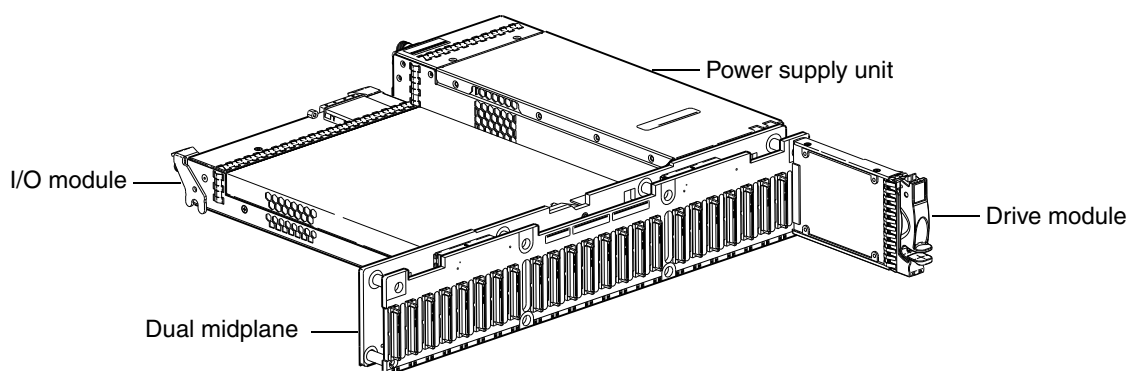

Figure 3 Storage system architecture — partial component assembly (2U24)

[Table 3](#) (below) and its supporting illustrations (following) describe 2732/2532/2332 FRUs.

Table 3 Available FRUs for 2002 Series products using 12-drive enclosure

Item	FRU description	Spares part number
1	DISK DRIVES	—
	a) 146-GB 3.5" SAS, 15K rpm (NEBS)	PFRUKF23-01
	b) 300-GB 3.5" SAS, 15K rpm (NEBS)	PFRUKF24-01
	c) 450-GB 3.5" SAS, 15K rpm (NEBS)	PFRUKF25-01
	d) 750-GB 3.5" SATA, 7.2K rpm (NEBS)	PFRUKF18-01
	e) 1-TB 3.5" SATA, 7.2K rpm (NEBS)	PFRUKF20-01
	f) 2-TB 3.5" SATA, 5.4K rpm (NK-L)	PFRUKF40-01
	g) AIR MANAGEMENT SLED (AMS), 3.5"	PFRUKF07-01
2	EAR KIT	—
	a) Left ear assembly	PFRUKK01-01
	b) Right ear assembly	PFRUKK02-01
3	CHASSIS	PFRUKA01-01
4	CONTROLLER MIDPLANE (included with chassis)	—

Table 3 Available FRUs for 2002 Series products using 12-drive enclosure

Item	FRU description	Spares part number
5	POWER SUPPLIES (one shown)	—
	a) AC DISK ENCL, POWER SUPPLY	PFRUKE01-01
	b) DC DISK ENCL, POWER SUPPLY	PFRUKE02-01
6	ENCLOSURE, CONTROLLER MODULE (one shown)	—
	a) 2732, FC, 1-RIOM, 1024-MB	PFRUKC13-01
	b) 2532, SAS, 1-RIOM, 1024-MB	PFRUKC14-01
	c) 2332, iSCSI, 1-RIOM, 1024-MB	PFRUKC21-01
7	SFP, XCVR (applies to 2722/2732 only)	PFRUKK06-01
8	CONTROLLER ENCLOSURE COVER (included with chassis)	—
Not shown	ENCLOSURE, I/O MODULE (ordered separately)	—
	a) 2130, 1-IOM, SAS Connection	PFRUKC03-01
	b) I/O module blank	PFRUKC04-01
Not shown	RAIL KIT (ordered separately, <i>not</i> included in BOM)	—
	Rack Mount Kit, Shelf, Short, All HW 22.5" - 31"	FHDW017-02
	Rack Mount Kit, Shelf, Long, All HW 25" - 36"	FHDW018-02
Not shown	CABLE KIT (Cable Pkg: SAS-8470 to mini-SAS-8088 4x0.6m)	PFRUKL02-01
Not shown	CABLE KIT (Cable Pkg: DB9-M to DB9-F; CLI (micro DB9))	PFRUKL01-01

 **NOTE:** See the following illustrations visually describe [Table 3](#) components:

- Exploded view — [Figure 4](#) on page 15
- Assembly — [Figure 5](#) on page 15
- Internal components assembly — [Figure 6](#) on page 16

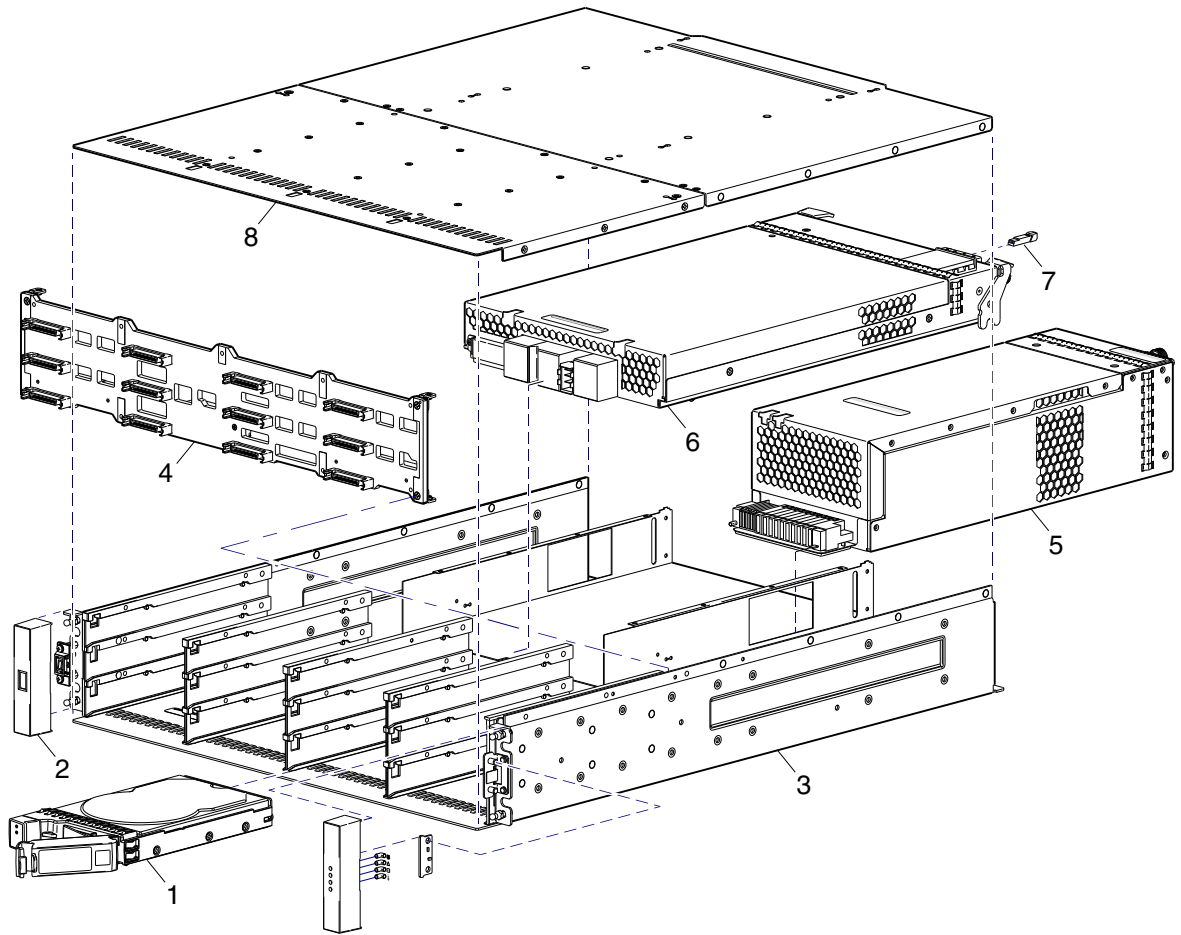

Figure 4 Storage system exploded view (2U12)

Figure 4 (above) and Figures 5 and 6 (below) illustrate 12-drive enclosure models: 2732/2532/2332.

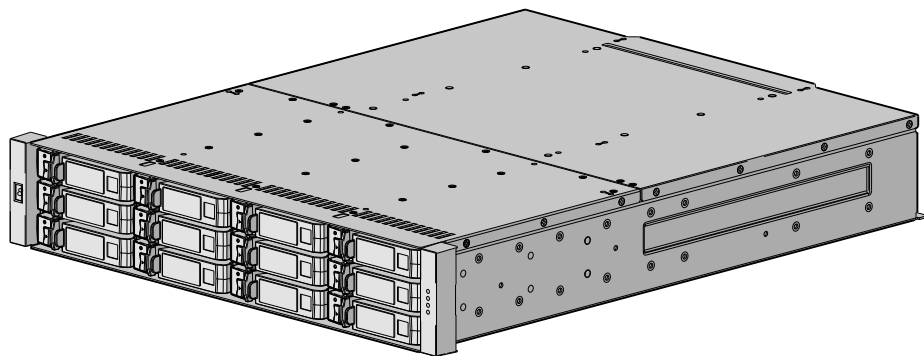

Figure 5 Storage system assembly (2U12)

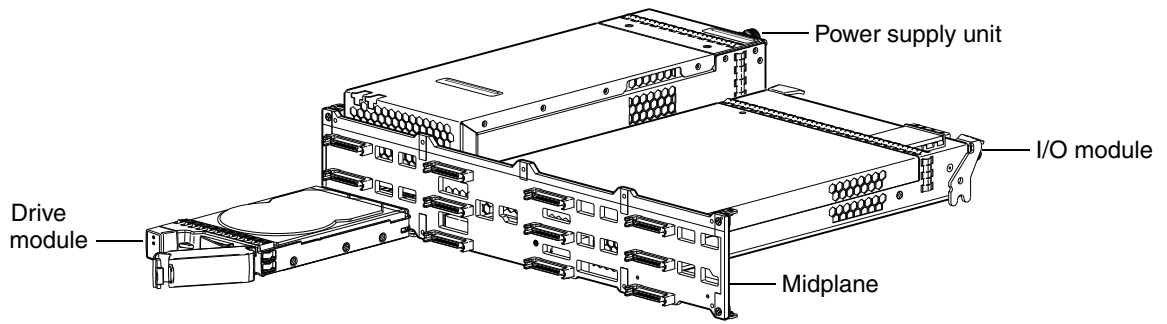

Figure 6 Storage system architecture — partial component assembly (2U12)

2 Procedures

This section provides procedures for replacing FRUs (field replaceable units). Each procedure addresses a specific replacement task. Before you begin *any* of the procedures, be mindful of the following static electricity precautions.

-
- △ **CAUTION:** Parts can be damaged by electrostatic discharge. Use proper anti-static protection:
- Keep the replacement component in the ESD bag until needed
 - Wear an ESD wrist strap grounded to an unpainted surface of the chassis
 - If an ESD wrist strap is unavailable, touch an unpainted surface of the chassis before handling the component
 - Never touch connector pins
-

Replacing a chassis

The chassis FRU replaces a damaged chassis or chassis components. A fully functional chassis requires successful installation of the following components:

- One or two controller modules (for a controller enclosure)
- All drives and air management sleds
- Two power supply units of the same type
- Two bezel ears
- One or two expansion modules (for a drive enclosure)

Replacement of chassis FRU components are described within this guide.

Replacing a controller or expansion module

In a dual-controller configuration, controller and expansion modules are hot-swappable, which means you can replace one module without halting I/O to virtual disks (vdisks) or powering off the enclosure. In this case, the second module takes over operation of the storage system until you install the new module.

In a single-controller configuration, I/O to vdisks must be halted, and the enclosure must be powered off. A controller/expansion module may need replacing when:

- The Fault/Service Required LED is illuminated
- Events in RAIDar indicate a problem with the module
- Troubleshooting indicates a problem with the module

Before you begin

-
- △ **CAUTION:** When replacing a controller module, ensure that less than 10 seconds elapse between inserting it into a slot and fully latching it in place. Failing to do so might cause the controller to fail. If it is not latched within 10 seconds, remove the controller module from the slot, and repeat the process.
-

Verifying partner firmware is enabled

In a dual-controller configuration, the storage system's partner firmware upgrade option is enabled by default, so when you upgrade a controller, the system automatically ensures that both controllers have the most recent version.

1. Log-in to the command line interface (CLI).
2. To verify that partner firmware upgrade is enabled, run the following command:

```
show advanced-settings
```

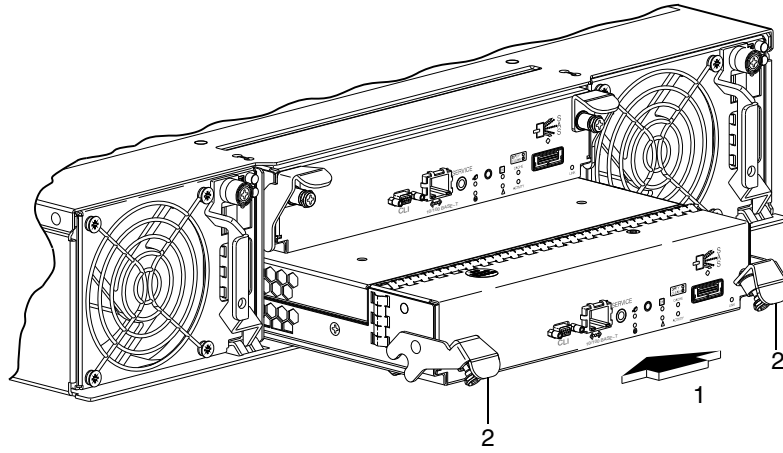



Figure 10 Inserting a controller module

IMPORTANT: In a dual-controller configuration, if the firmware versions differ between the two controllers, partner firmware upgrade brings the older firmware to the later revision level.

Verifying component replacement

After replacing the controller module, check that the FRU OK LED (back) illuminates green, indicating that the controller has completed initializing, and is online/operating normally.

If the enclosure's Unit Locator LED is on, run the following command to turn it off:

```
set led enclosure 1 off
```

If the Fault/Service Required LED is amber, the controller module has not gone online, and likely failed its self-test. Put the module online by restarting a controller, or by checking the event log for errors. To restart the controller, run the following command:

```
restart sc a/b
```

Installing a controller (additional module)

Single-controller enclosures can be upgraded to dual-controller status. See [Removing a controller module](#) on page 19 for instruction on installing an additional controller module.

Replacing a drive module

A drive module consists of a disk drive in a sled. Drive modules are hot-swappable, which means they can be replaced without halting I/O to the vdisks, or powering off the enclosure. The new drive module must be of the same type, and possess capacity equal to or greater than the one being replaced.

Before you begin

CAUTION: Removing an air management module impacts the airflow and cooling ability of the device. To avoid potential overheating, insert the new drive module as quickly as possible. If the internal temperature exceeds acceptable limits, the enclosure may overheat, and automatically shut down or restart.

See [Parts can be damaged by electrostatic discharge. Use proper anti-static protection:](#) on page 17.

Removing air management modules

1. Squeeze the latch release flanges inward to disengage the drive module (see [Figure 11](#)).

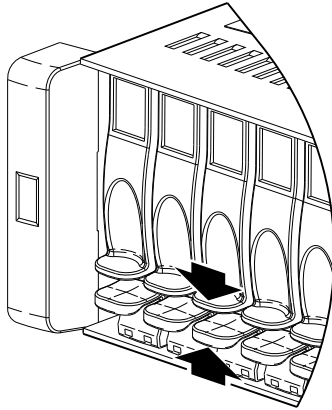

SFF 2.5" drive sled

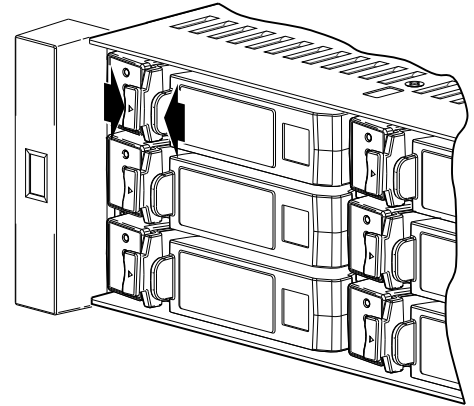

LFF 3.5" drive sled

Figure 11 Disengaging an air management sled (AMS)

2. Wait 20 seconds for the internal disks to stop spinning.
3. Pull the drive module straight out of the chassis see [Figure 12](#)).

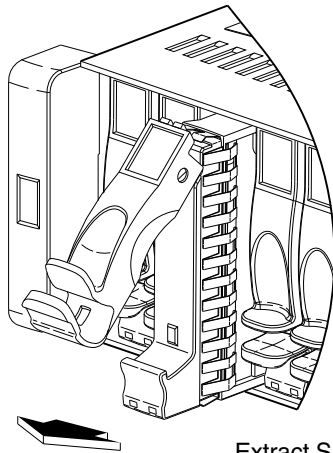

Extract SFF AMS

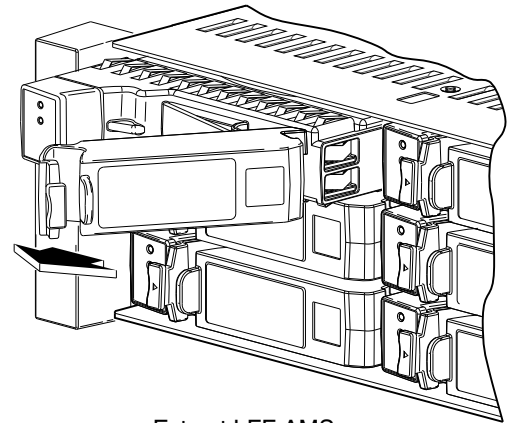

Extract LFF AMS

Figure 12 Removing an AMS

Installing drive modules

1. Squeeze the latch release flanges together, and then pull the latch, rotating it outward until it is fully open (see [Figure 11](#) on page 21).
2. Follow *one* of the two sub-steps below, according to your product's drive type:
 - a. SFF drive — with the LEDs oriented to the bottom, slide the drive module into the drive slot as far as it will go (see left illustration in [Figure 13](#) on page 22).
Proceed to step 3 below.

- b. LFF drive — with the LEDs oriented to the left, slide the drive module into the drive slot as far as it will go (see right illustration in [Figure 13](#) on page 22).

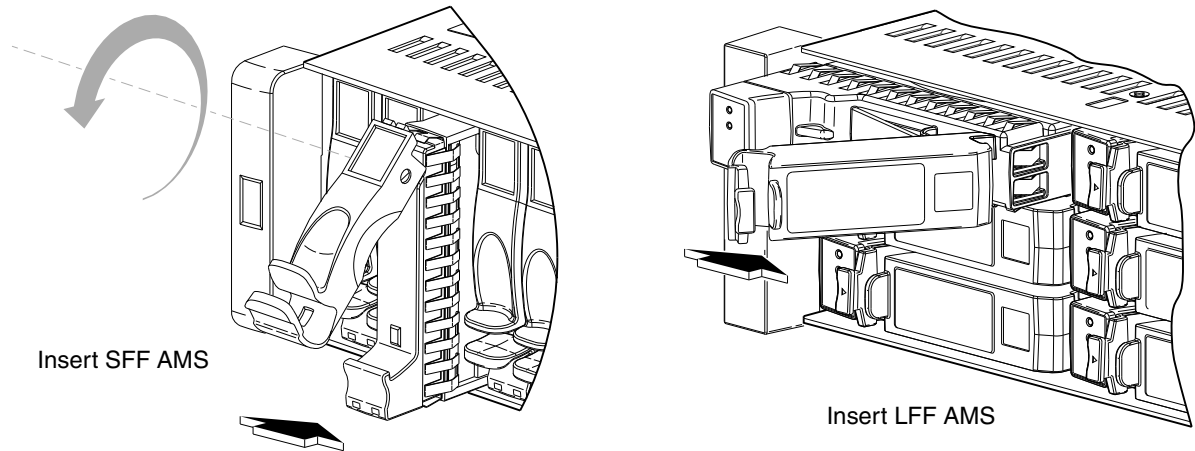

Figure 13 Installing a drive module

3. Rotate the latch inward until it clicks closed to firmly seat the drive module in the enclosure's midplane.

The drive modules should now appear as shown in [Figure 11](#) on page 21.

4. Use the RAIDar status page (*Manage > Vdisk Configuration > Disk Drive Status*) to check the status of the drive.

Verifying component installation

Check that the Power/Activity/Fault LED — located on the drive — is illuminated green. On SFF drives, this LED is located at bottom/left. On LFF drives, the LED is located at top/left. Both LEDs are shown in [Figure 13](#) above.

Replacing a power supply unit

This section details procedures for replacing a failed AC or DC power supply unit (PSU).

-
- △ **CAUTION:** Power supply FRU replacement activities can cause an enclosure's cables to disconnect and disks to go offline.
-

Therefore, before installing or replacing a FRU, you should stop I/O to all vdisks. If stopping I/O is not possible, the replacement or installation should be deferred. If immediate replacement is necessary, ensure that all cables are secured, and carefully move the enclosures.

Verifying component failure

When either a fan or power supply component fails, RAIDar provides notification, faults are recorded in the event log, and the PSU's status LED color changes to amber to indicate a fault condition.

Before you begin

-
- △ **CAUTION:** Removing a power supply unit significantly disrupts the enclosure's airflow; therefore, do not remove the PSU until you have the replacement module.
-

See [Parts can be damaged by electrostatic discharge. Use proper anti-static protection:](#) on page 17.

Disconnecting a power cable

1. Before disconnecting power cables, shut off the main circuit breaker in the rack.

2. Power off all enclosure switches.
For DC power cables, perform [step 3](#) below. For AC power cables perform [step 4](#) below.

DC power cables:

3. Loosen the cable-locking screws that attach each D-shell connector to its power supply:
 - a. Carefully disconnect the power cable from the DC power source.
 - b. Loosen the cable-locking screws attaching the D-shell connector to the PSU.
 - c. Disconnect the power cable from the PSU.

AC power cables:

4. Disconnect the power cord from the power supplies:
 - a. Disconnect the male plug from the rack power source.
 - b. Disconnect the female plug from the AC PSU.

Removing a power supply

1. Set the power switch on the power supply module to the Off position.
2. Turn the thumbscrew at the top of the latch counterclockwise to loosen and disengage it from the module; however, do not remove the thumbscrew from the latch.
3. Rotate the latch downward to 45 degrees, supplying leverage to disconnect the module from the internal connector.

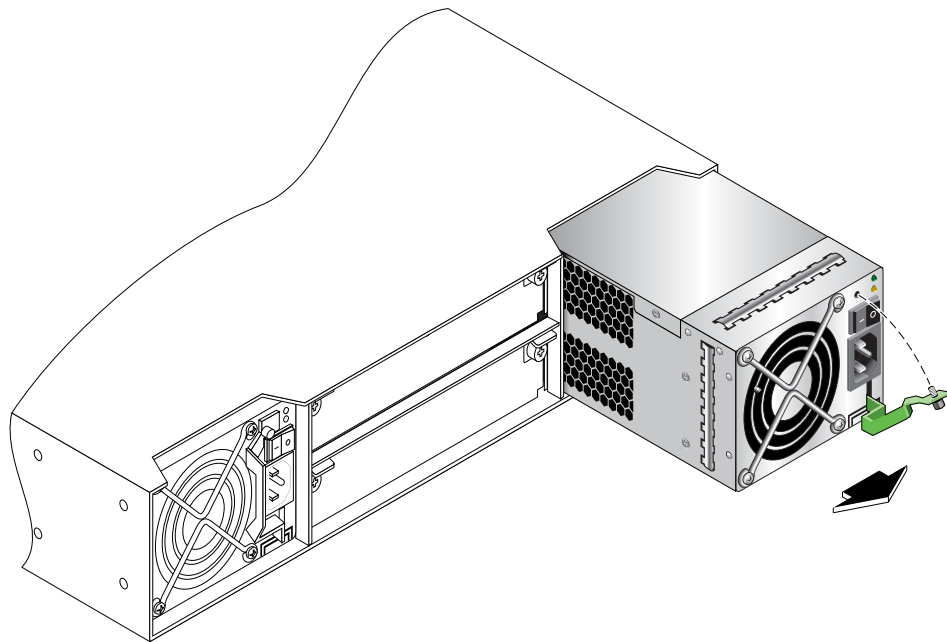

Figure 14 Removing a power supply unit

4. Use the latch to pull the module straight out of the chassis.

IMPORTANT: Do not lift the module by its latch; doing so could break the latch. Lift and carry the module using its metal casing.

Installing a power supply unit

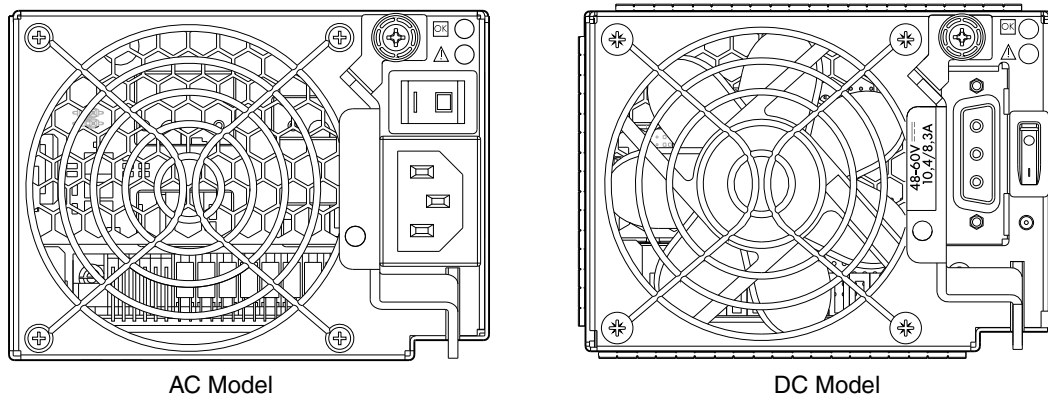

Figure 15 Orienting a power supply unit

To install a power supply module, perform the following steps:

1. Orient the PSU with the AC or DC connector and power switch toward the right as shown in [Figure 14](#) on page 23 and [Figure 15](#) on page 24, respectively.
2. Slide the module into the power supply slot as far as it will go.
3. Rotate the PSU latch upward until it is flush against the PSU face, ensuring that the connector on the PSU engages the connector inside the chassis.
4. Turn the thumbscrew located at the top of the power supply latch clockwise, until it is finger-tight, to secure the latch to the power supply unit within the enclosure.

Connecting a power cable

1. Before connecting DC power cables, shut off the main circuit breaker in the rack.
2. Power off all enclosure switches.
For DC power cables, perform [step 3](#) below. For AC power cables perform [step 4](#) below.

DC power cables:

3. Install the power cable:
 - a. Attach the D-shell to the DC PSU cable connector, and tighten the screws, applying a torque between 1.7 N-m (15 lb-in) and 2.3 N-m (20 lb-in), to securely attach the cable to the DC PSU.
 - b. Secure the other end of the DC power cable to the DC power source. When connecting to the power source, take care to secure the wires according to the cable labels, as described in the admonition below.

AC power cables:

4. Install the power cord:
 - a. Connect the female plug to the AC PSU cord inlet.
 - b. Connect the male plug to the rack power source.
 - c. Connect the primary power cords from the rack to separate external power sources.

DC Model

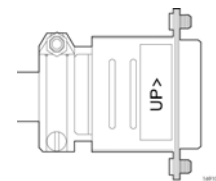

D-shell
Connector

AC Model

Power supply
module

Rack power
source

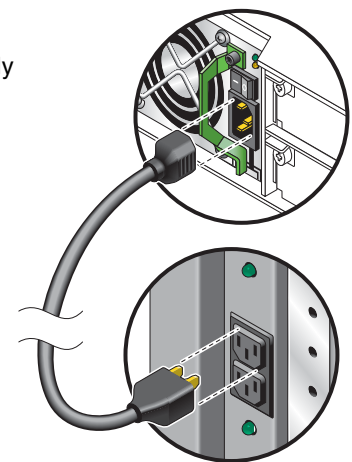

IMPORTANT: Check the DC cable labels before connecting each cable to its source. One wire is labeled *ground*; the other two are labeled *positive* and *negative*.

Replacing bezel ears

Before you begin

△ **CAUTION:** Verify that you have the proper FRU kit (left or right) for the ear that is being replaced.

See [Parts can be damaged by electrostatic discharge. Use proper anti-static protection:](#) on page 17.

Enclosure bezel ear FRUs are available for the left and right ears of the chassis front panel. The following bezel ear replacement procedure applies to ear kits provided with the 2U24 and 2U12 enclosure models, respectively. Refer to the following illustration(s) pertaining to your product's ear kit.

💡 **TIP:** See the R/Evolution 2002 Series Setup Guide for LED descriptions.

Figure 16 illustrates bezel ear kit replacement relative to 2U24 models. See [Removing the bezel ears](#) on page 26, and [Installing the bezel ears](#) on page 26.

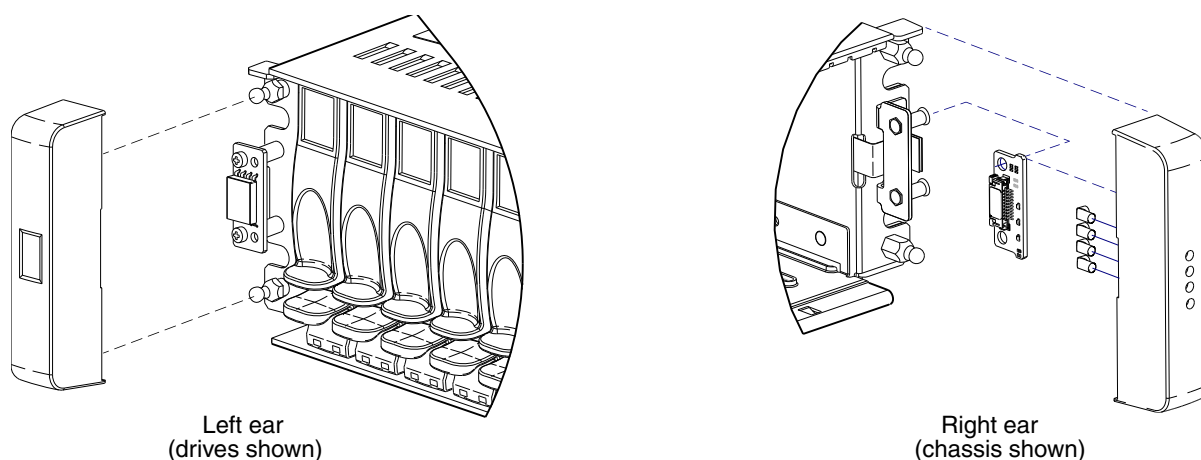

Figure 16 Replacing bezel ears — 2U24 models

Figure 17, and Figure 18 on page 26 illustrate bezel ear kit replacement relative to 2U12 models. See [Removing the bezel ears](#) on page 26, and [Installing the bezel ears](#) on page 26.

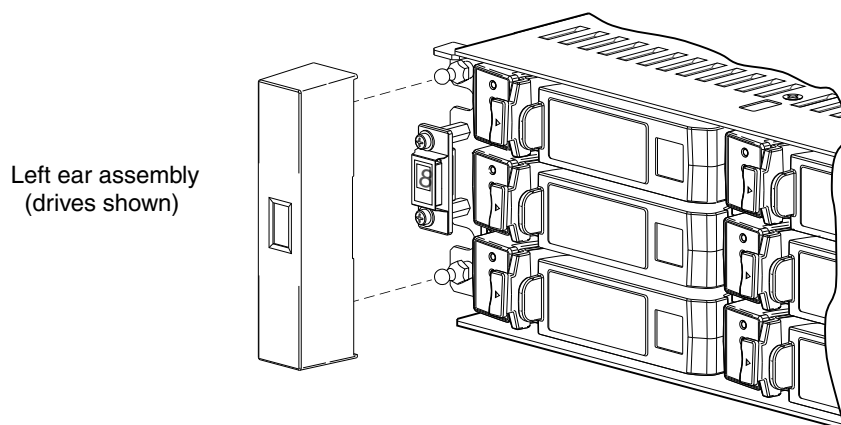

Figure 17 Replacing left bezel ears — 2U12 models

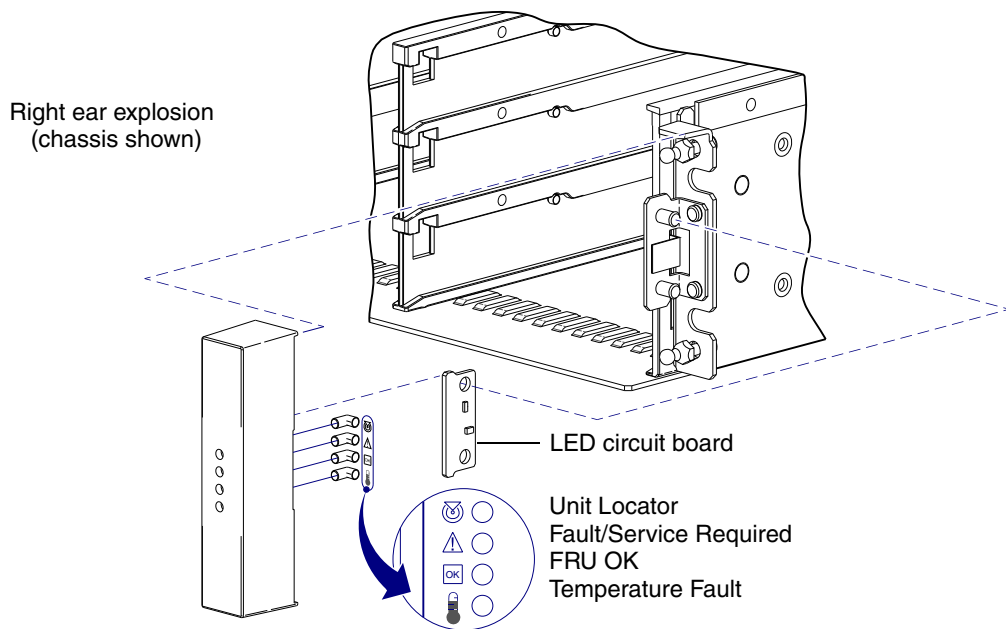

Figure 18 Replacing right bezel ears — 2U12 models

Removing the bezel ears

See [Figure 16](#) on page 25, [Figure 17](#) on page 25, and [Figure 18](#) when removing the bezel ear sub-assemblies.

1. Power off the enclosure.
2. Gently squeeze the sides of the ear cover, and pull it straight forward to remove the ear from the push-fit mounting studs.
3. Loosen the hexagonal nuts that secure the LED circuit board to the mounting pins on the flange.
4. Remove the LED circuit board.

[Figure 18](#) lists LEDs common to the right ear of *both* 2U24 and 2U12 enclosures.

 **TIP:** See the R/Evolution 2002 Series Setup Guide for a description of front panel LEDs.

Installing the bezel ears

See [Figure 16](#) on page 25, [Figure 17](#) on page 25, and [Figure 18](#) when installing the bezel ear sub-assemblies.

1. Power off the enclosure.
2. Install the LED circuit board
 - a. Insert the mounting pins into the though holes in the LED circuit board and mounting flange.
 - b. Thread the hexagonal nuts onto the inserted pins, and turn the nuts clockwise to tighten.
3. Gently slip the ear cover over onto the push-fit mounting studs, taking care to guide the LED indicators through the cover's through holes.
4. Power on the enclosure

Replacing a Fibre Channel SFP

This section provides steps for removing a small form-factor pluggable (SFP transceiver) connector used in a Fibre Channel (FC) controller host port. See Figure 12 when removing and installing an SFP.

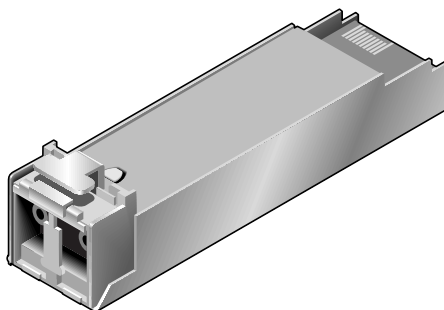

Figure 19 Typical SFP module

Before you begin

△ **CAUTION:** Mishandling fibre-optic cables can degrade performance. Do not twist, fold, pinch, or step on fibre-optic cables. Do not bend them tighter than a 2-inch radius.

See [Parts can be damaged by electrostatic discharge. Use proper anti-static protection:](#) on page 17.

Removing an SFP module

1. Disconnect the fibre-optic interface cable by squeezing the end of the cable connector.
If removing multiple cables, make sure they are labeled before removing them. To prevent possible loss of access to data, be sure to remove the correct cable and SFP.
2. If the SFP does not have a cable, it should have a plug. Remove the plug and retain it for future use.
3. SFPs are commonly held in place by a small wire bail actuator. Pull down on the top of the bail and rotate it in the downward direction.
4. Grasp the SFP between your thumb and index finger, and carefully remove it from the controller module.

Installing an SFP module

1. To connect to an empty port, slide the SFP connector into the port until it locks into place.
2. Plug the cable's SFP connector into the duplex jack at the end of the SFP.

Index

Numerics

2002 Series

product line (2U12/2U24) [9](#)

2U12 [11](#)

2332 iSCSI [9](#)

2532 SAS [9](#)

2732 FC [9](#)

2U24 [11](#)

2322 iSCSI [9](#)

2522 SAS [9](#)

2722 FC [9](#)

A

audience [9](#)

B

brand

R/Evolution [9](#)

C

conventions

document [10](#)

D

document

conventions [10](#)

prerequisite knowledge [9](#)

related documentation [9](#)

E

electrostatic discharge [17](#)

Ethernet [9](#)

F

Fibre Channel Controller Enclosure [9](#)

FRUs

available for 2002 Series [11](#)

12-drive enclosure [13](#)

24-drive enclosure [11](#)

enclosure assembly

2U12 [15](#)

2U24 [13](#)

illustrated parts breakdown

2U12 [15](#)

2U24 [12](#)

internal components assembly

2U12 [16](#)

2U24 [13](#)

Interoperability Matrix (CRC) [11](#)

P/N tables [11](#)

H

host interface protocols

FC [9](#)

iSCSI [9](#)

SAS [9](#)

I

iSCSI Controller Enclosure [9](#)

P

prerequisite knowledge [9](#)

procedures

general precaution [17](#)

replacing a chassis [17](#)

replacing a controller or expansion module [17](#)

replacing a drive module [20](#)

replacing a fibre channel SFP [27](#)

replacing a PSU [22](#)

replacing bezel ears [25](#)

product line

2002 Series [9](#)

R

related documentation [9](#)

S

SAS Controller Enclosure [9](#)

W

web sites

Dot Hill documentation [9](#)

Interoperability Matrix [11](#)

